







DATASHEET

3FG15

v1.6

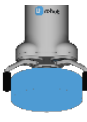
1. Datasheet

1.1. 3FG15

General Properties		Minimum	Typical	Maximum	Unit
Payload Force Fit 	Grip	- -	- -	10 22	[kg] [lb]
	Flexible grip	- -	- -	8 17	[kg] [lb]
Payload Form Fit 		- -	- -	15 33	[kg] [lb]
Grip Diameter*	External 	4 0.16	- -	152 5.98	[mm] [inch]
	Internal 	35 1.38	- -	176 6.93	[mm] [inch]
Finger position resolution		- -	0.1 0.004	- -	[mm] [inch]
Diameter repetition accuracy		- -	0.1 0.004	0.2 0.007	[mm] [inch]
Gripping force	Grip	10	-	240	[N]
	Flexible grip	10	-	140	[N]
Gripping force (adjustable)		1	-	100	[%]
Gripping speed (diameter change)		-	-	125	[mm/s]
Gripping time (including brake activation)**		-	500	-	[ms]
Minimum necessary finger movement		3	-	-	[mm]
Hold workpiece if power loss?		Yes			
Storage temperature		0	-	60	[°C]
		32	-	140	[°F]
Motor		Integrated, electric BLDC			
IP Classification		IP67			
Dimensions [L, W, Ø]		156 x 158 x 180			[mm]
		6.14 x 6.22 x 7.08			[inch]
Weight		1.15			[kg]
		2.5			[lb]

* With the scope of delivery.

** 10 mm diameter distance. Also see section [Gripping methods](#).

Operating Conditions	Minimum	Typical	Maximum	Unit
Power supply	20	24	25	[V]
Current consumption	43	-	1500 ***	[mA]
Operating temperature	5	-	50	[°C]
	41	-	122	[°F]
Relative humidity (non-condensing)	0	-	95	[%]
Calculated operation life	30 000	-	-	[Hours]

*** 600 mA set as default.

Fingers

The supplied fingers can be mounted in 3 different positions to achieve different **Gripping Forces** and different **Gripping Diameters**.

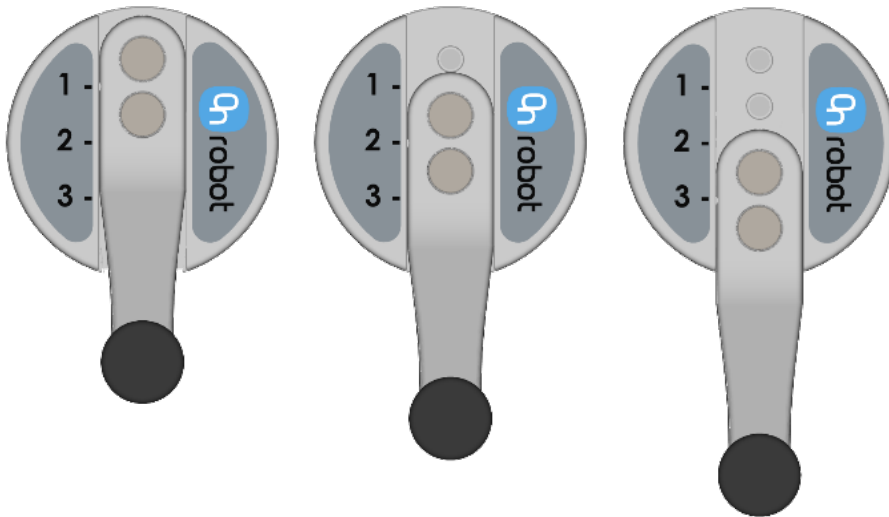

The delivered finger length is 49 mm (L in the drawing below). If custom fingers are required, they can be made to fit the gripper according to the dimensions (mm)[inch] shown below. The needed screws are M4x8mm (use 3 Nm tightening torque):

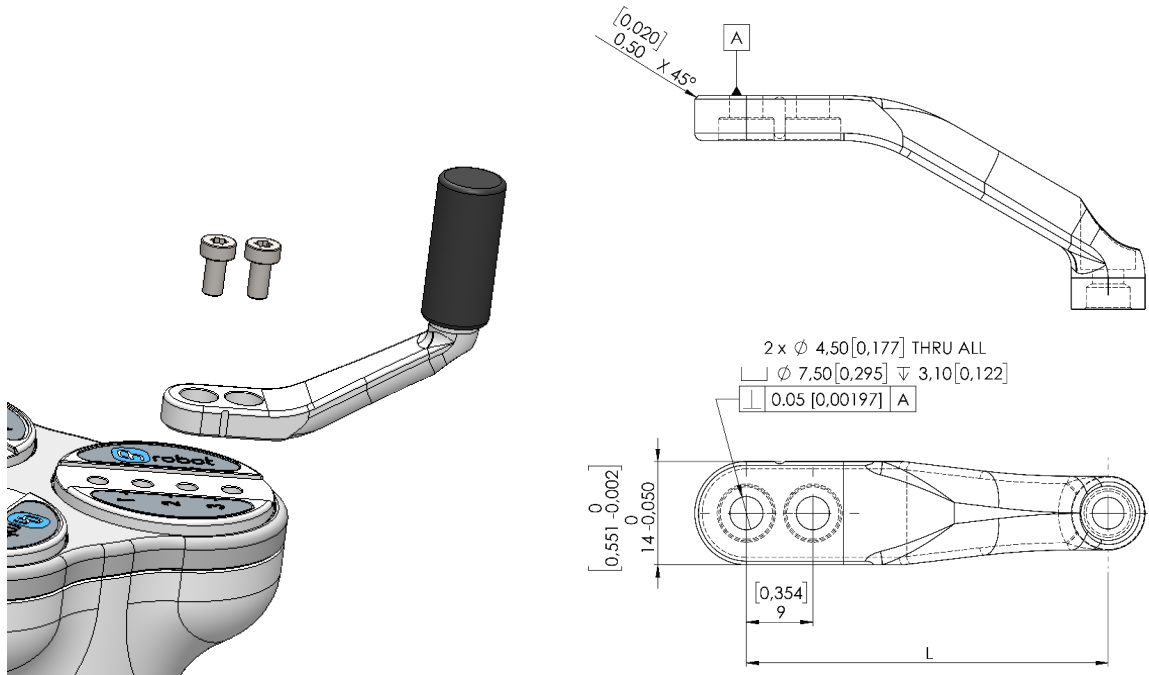

Fingertips

The supplied fingertips are listed below. Different fingertips will allow to achieve different **Gripping Forces** and different **Gripping Diameters**.

- $\phi 10$ mm steel
- $\phi 13$ mm steel
- $\phi 13.5$ mm silicone
- $\phi 16.5$ mm silicone

If custom fingertips are required, they can be made to fit the gripper's fingers according to the dimensions (mm)[inch] shown below. The needed screws are M4x8mm (use 2.5 Nm tightening torque):

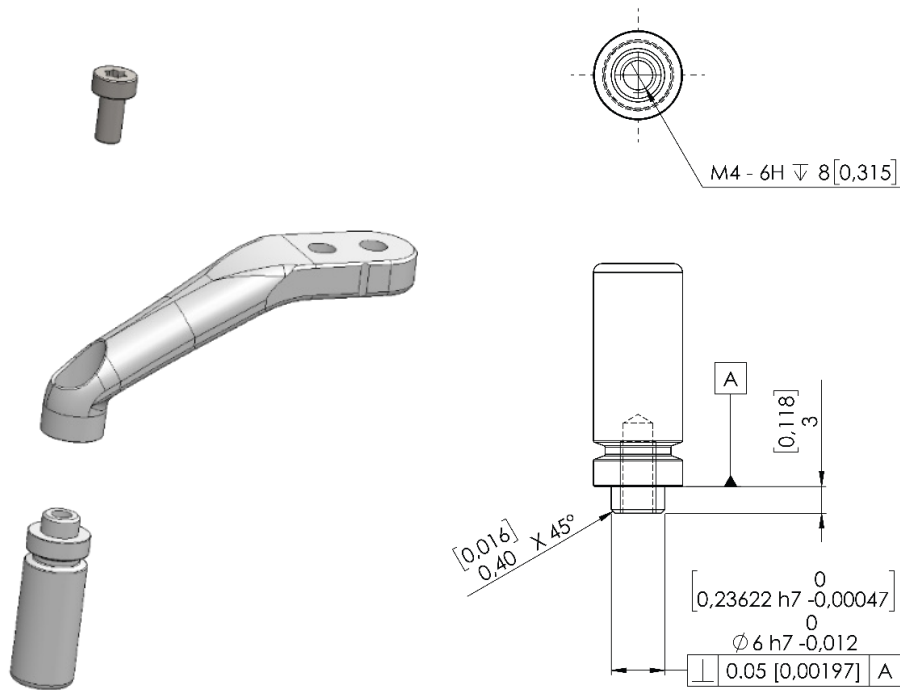

In the graph below, the maximum payload allowed for customized fingertip given a length is shown.

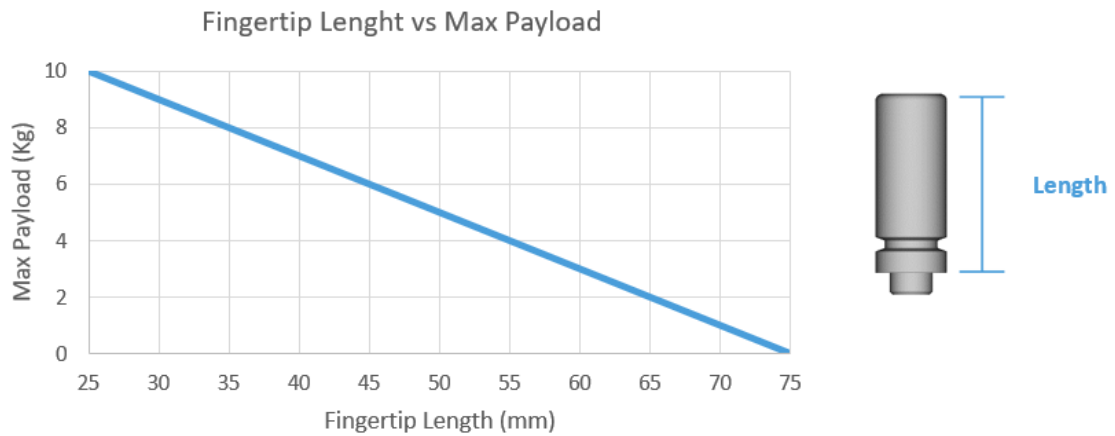

In the graph below, how the % of maximum achievable force decreases as the finger length increases when customized fingertips are used.

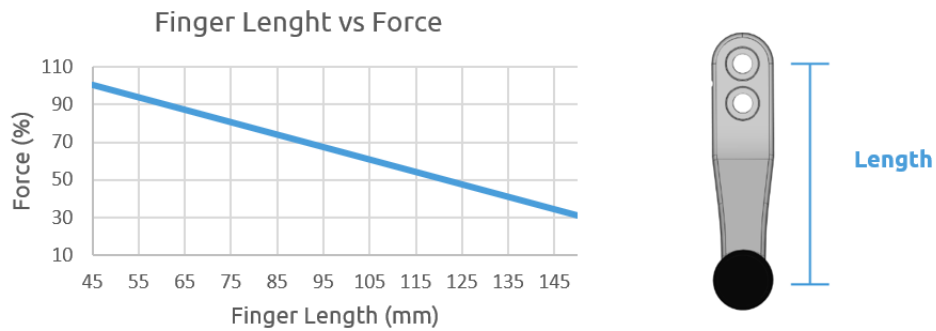

X-shape Fingertips

These fingertips improve the gripper's ability to pick and place round workpieces with collar like features. By combining the force fit and the form fit gripping approaches, the fingertips increase the stability and payload of the workpiece to be gripped.

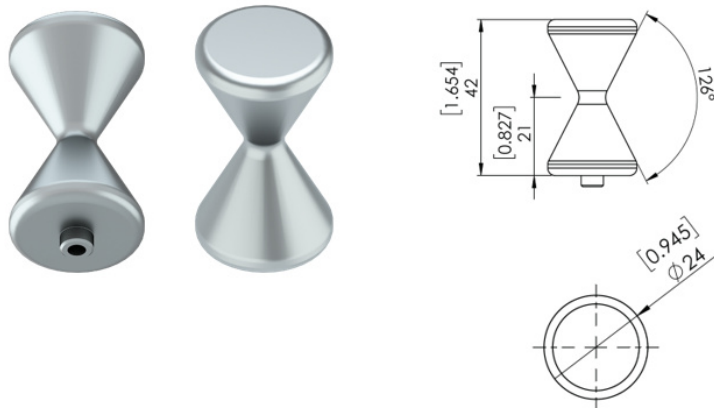

When these fingertips are used, set the fingertip diameter to 16 mm in the robot program. These fingertips are optional accessories and need to be purchased separately. To purchase these fingertips, please contact the distributor.

- 3FG X-Shape Fingertips PN 106963.

Knurled Fingertip Set

Designed with a knurled surface, these fingertips increase friction and payload capacity, making them optimal for gripping and moving raw and oil-coated workpieces in CNC machines.



NOTE:

The knurled fingertip may leave marks on the material.

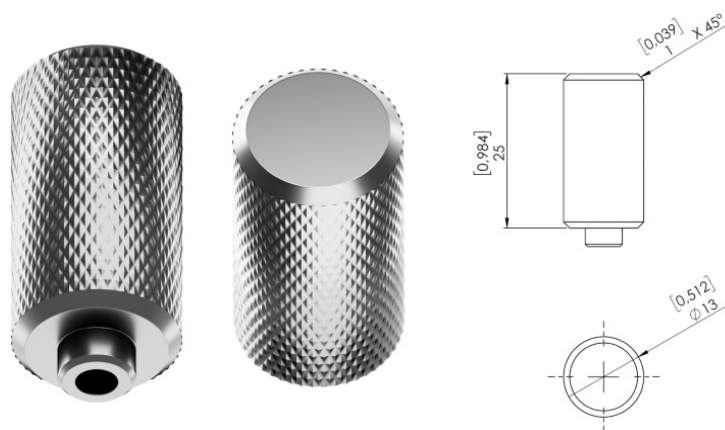

Set the robot program to a 13 mm diameter when using these fingertips. They are optional accessories, sold separately. Contact the distributor for purchase.

- Knurled Fingertip Set PN 113929.

Internal/External grips

In the document the internal and external grip terms are used. These grips are related to how the workpiece is gripped.

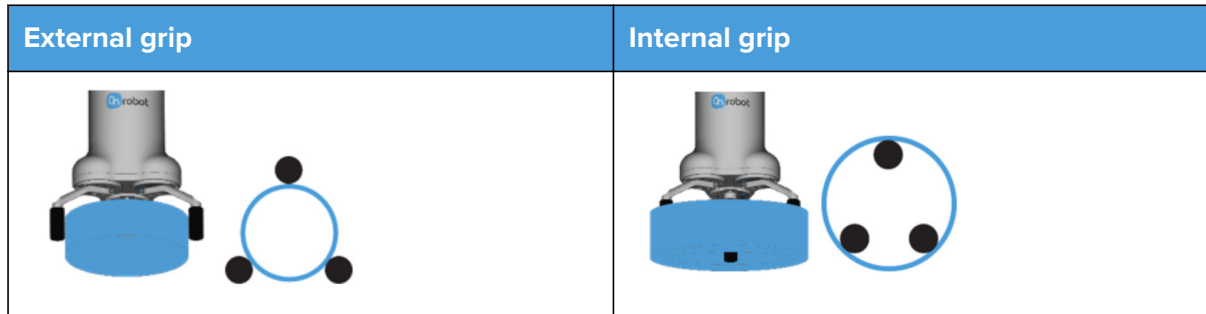

Gripping methods

There are two different gripping methods how the 3FG15 can be operated. With each method, both internal and external gripping can be used.

Normal grip	Flexible grip
<p>Use this gripping method if:</p> <ul style="list-style-type: none"> • the diameter of the object is known and does not vary • more than 140 N gripping force is needed 	<p>Use this gripping method if:</p> <ul style="list-style-type: none"> • the diameter of the object is not known or varies significantly • up to 140 N gripping force is sufficient

Normal grip

The gripping action has two phases:

Phase 1: For a safety reason, the fingers will start moving with a lower force (<140 N) to avoid damaging anything that could get clamped between the gripper fingers and the workpiece. The 3FG15 will apply a force of 50 N during this phase.

Phase 2: When the gripper diameter is very close to the programmed target diameter, the gripper will increase the force to grip with the programmed target force. After the grip, a brake will be activated (tic sound). The activation of the brake, also known as, Force grip detected, can be verified in the provided functions. This brake will hold the workpiece with the applied force, with no power consumption and holding the workpiece in case of power loss. This brake will automatically be deactivated when the gripper performs a release or a new grip command. While programming the gripper, the brake can be deactivated by using the features in the GUI.

Flexible grip

The fingers will start moving with the set target force. If the gripper gets in contact with the object, it will grip with the programmed target force. After the grip, a brake will be activated (tic sound). The activation of the brake, also known as, Force grip detected, can be verified in the provided functions. This brake will hold the workpiece with the applied force, with no power consumption and holding the workpiece in case of power loss. This brake will

automatically be deactivated when the gripper performs a release or a new grip command. While programming the gripper, the brake can be deactivated by using the features in the GUI.



NOTE:

The achievable gripping speed is affected by the following parameters:

1. Using lower target force (F) than 100% can reduce the gripping speed.
2. The size of the target diameter: the bigger the target diameter (gripping near to fully open position), the lower the achievable gripping speed.

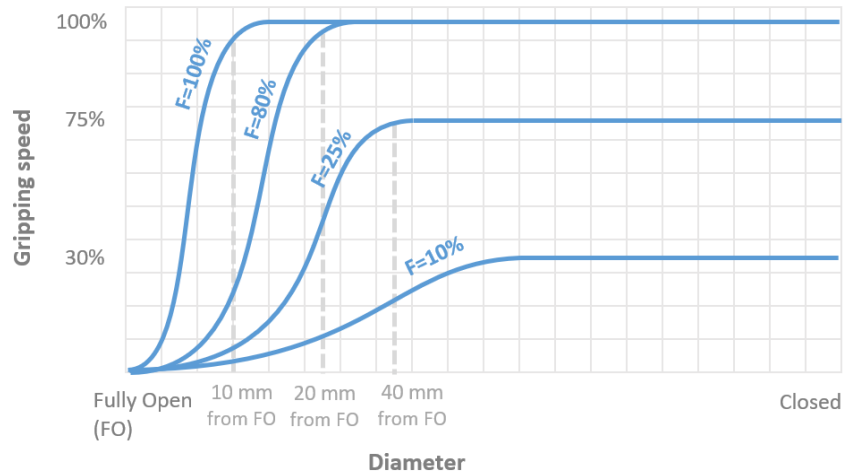

Gripping Force

The total gripping force highly depends on the finger angle θ . For both internal and external grip, the lower the finger angle, the higher the force that will be applied as shown in the graph below.

Although the fingers can move from 0 to 180, the angle range of an external grip is 30°-165° and for an internal grip 20°-160°

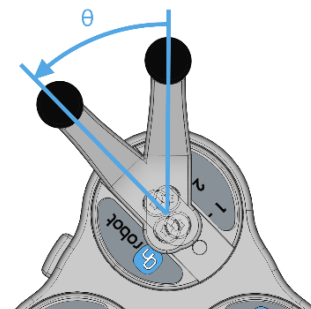

Maximum Force and Finger Angle θ

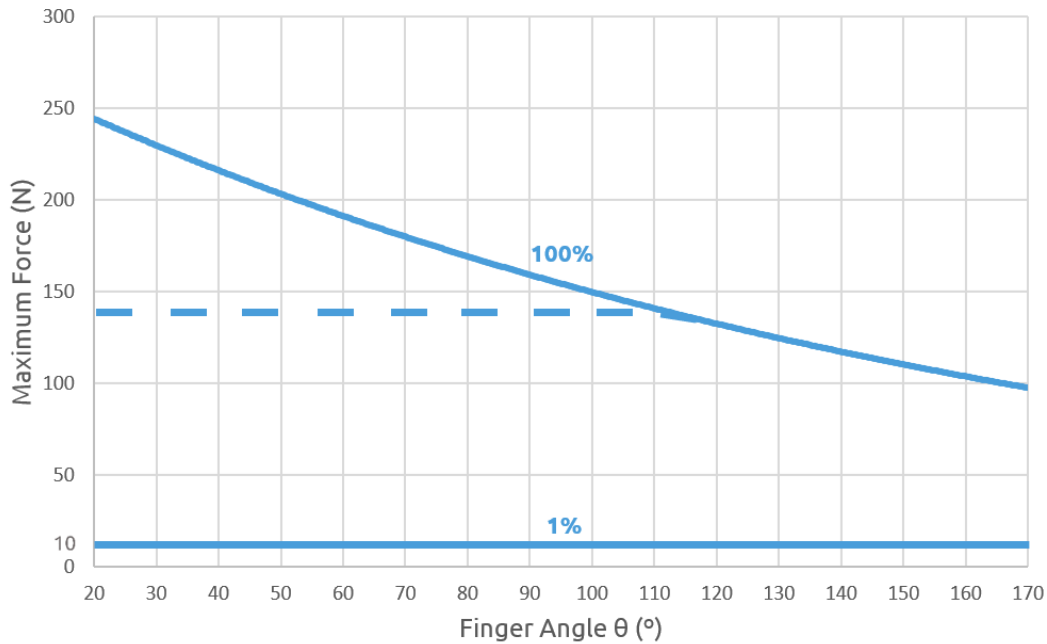

Graph plotted using measurements with 1 A current, silicone fingertips and a metal workpiece. The percentages shown on the graph stand for the target force percentage. The blue line stands for the normal Grip function and the dashed line stands for the Flexible grip function.



NOTE:

The total force applied depends on the finger angle, the input current (limited in some robots' tool flange connection) and the friction coefficient between the materials of the fingertips and the workpiece.

Gripping Diameter

The different configurations of the delivered finger and fingertips allow to achieve a wide range of diameters.

Finger Position	Fingertip (mm)	External Gripping range (mm)	Internal Gripping range (mm)
1	Ø10	10 - 117	35 - 135
	Ø13	7 - 114	38 - 138
	Ø16.5	4 - 111	41 - 140
2	Ø10	26 - 134	49 - 153
	Ø13	23 - 131	52 - 156
	Ø16.5	20 - 128	55 - 158
3	Ø10	44 - 152	65 - 172
	Ø13	41 - 149	68 - 174
	Ø16.5	38 - 146	71 - 176

Based on:

- Angle for external gripping min 165° (Pos 1), 163 ° (Pos 2), 161 ° (Pos 3) and max 30° (all 3 positions)
- Angle for internal gripping min 160° and max 30°

The closer to the maximum diameter range, the lower the angle and, therefore, the higher the force.

1.2. 3FG15

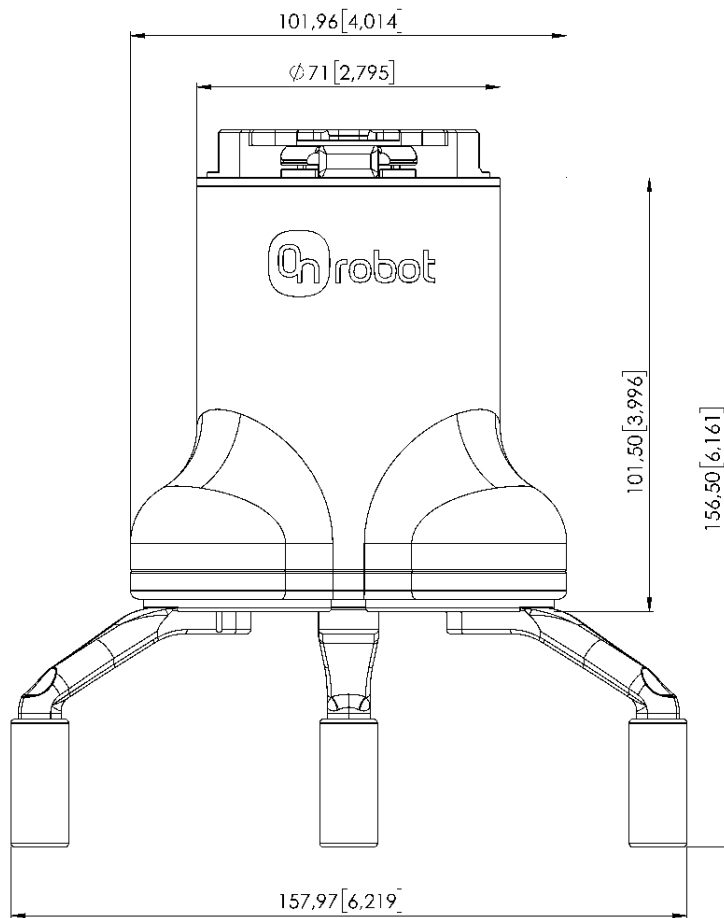

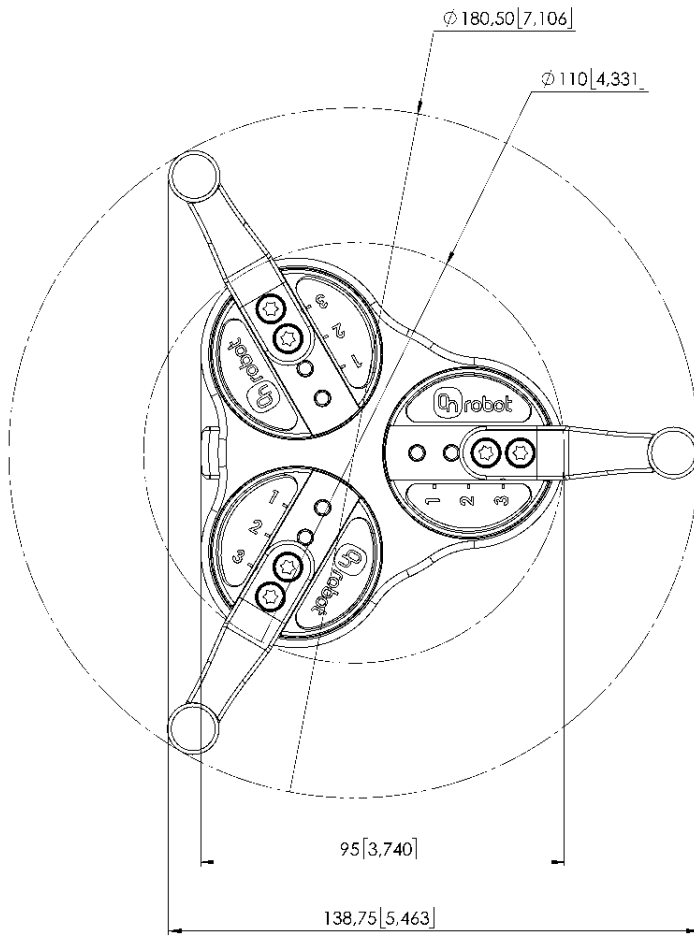

All dimensions are in mm and [inches].